



DEVELOPING TOMORROW'S TODAY

WE-LOCK CO.

AN ISO 9001 : 2008 / ISO 14001 / ISO 18001 CERTIFIED COMPANY

BUTTWELD FITTINGS





WE-LOCK CO.

AN ISO 9001 : 2008 / ISO 14001 / ISO 18001 CERTIFIED COMPANY

BUTT WELD FITTINGS TO ANSI B16.9 & 16.28

Dimensions

Dimensions of Elbows, Tees, Caps and Reducers from 1/2" NB to 60" short Radius Elbows and Return Bends from Bends from 1" to 24" N.B. and Long Radius Bends from 1/2" N.B. to 24 are as stated in the current editions of ANSI B 16.9 and B-16.28 wall thickness are as listed ANSI B 36.10M.

Material

Stainless Steel : ASTM A403, WP 304 / 304L / 304H / 316 / 316L / 317 / 317L / 321 / 310 / 347 / 904L etc.

Carbon Steel : ASTM A234 WPB / A420 WPL3 / A420 / WPL6 / MSS-SP-75 WPHY 42 / 46 / 52 / 56 / 60 / 65 / 70

Alloy Steel : ASTM A234 WP1 / WP5 / WP9 / WP11 / WP22 / WP91 etc.

Manufacture & Heat Treatment

In accordance with the relevant ASTM or MSS Specification.

Weld Preparation

All fittings have a weld preparation to ANSI B 16.25

Marking

Fittings are marked with : the nominal size (or sizes) ; schedule or wall thickness; material grade; that reference manufacturer's mark. Where the size of fittings does not permit full marking then nominal size(s); schedule or wall thickness; and material grade are omitted.

Test Certificate

Fittings test certificates are available and are supplied with all goods. Test Certificates include full chemical analysis and Mechanical Properties with 3.1 Certificate, Impact Test & NACE MR 0175 / MR 0103 in addition as per requirement.

Inspection

All stock is statically sample inspected on receipt. The sampling plan is selected from BS6001.

OTHER PRODUCTS AVAILABLE

Other Schedules / wall thicknesses Nickel base alloys, Copper, Nickel & Duplex are available from short delivery time.





WE-LOCK CO.

AN ISO 9001 : 2008 / ISO 14001 / ISO 18001 CERTIFIED COMPANY

DIMENSION OF BUTT WELDING FITTINGS TO ANSI B 16.9/MSS SP 43

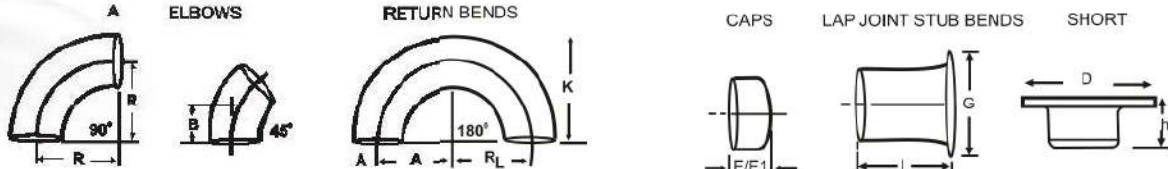

NOM BORE	PIPE OD	RADIUS 'R'					LENGTH 'L'					
		1 D	1.5 D	B 1.5 D	K	E/E1	G	MSS SP 43	ANSI B 16.9	D	H	
1/2	21.3	12.7	38.1	15.9	48	25.4	34.9	50.8	76.2	45	8	
3/4	26.7	19.05	38.1	19.0	51	25.4	42.8	50.8	76.2	54	8	
1	33.4	25.4	38.1	22.2	56	38.1	50.8	50.8	101.6	64	10	
1 1/4	42.1	31.75	47.6	25.0	70	38.1	63.5	50.8	101.6	74	12	
1 1/2	48.3	38.1	57.15	28.6	83	38.1	73.0	50.8	101.6	84	12	
2	60.3	50.8	76.2	35.0	106	44*	92.0	63.5	152.4	102	16	
2 1/2	73.0	63.5	95.25	44.0	132	51	106	63.5	152.4	122	16	
3	88.9	76.2	114.3	50.8	159	64*	127.0	63.5	152.4	138	18	
3 1/2	101.6	88.9	133.35	57.2	184	76*	139.7	76.2	152.4	148	18	
4	114.3	101.3	152.4	63.5	210	76*	157.2	76.2	152.4	158	20	
5	141.3	127.0	190.5	79.4	262	89*	185.7	76.2	208.2	188	20	
6	168.3	152.4	228.6	95.3	313	102*	218	88.9	203.2	212	25	
8	219.1	203.2	304.8	127.0	414	127*	270.0	101.6	203.2	270	30	
10	373.1	254.0	381.0	158.7	518	152*	324.0	127.0	254.0	325	30	
12	323.9	304.8	457.2	190.5	619	178*	381.0	152.4	254.0	380	35	
14	355.6	355.6	533.4	222.2	711	191*	412.8	152.4	305.0	415	40	
16	406.4	406.4	609.6	254.0		203*	470.0	152.4	305.0	470	40	

NOM BORE	PIPE OD	RADIUS 'R'					LENGTH 'L'					
		1 D	1.5 D	B 1.5 D	K	E/E1	G	MSS SP 43	ANSI B 16.9	D	H	
18	457.2	457.2	685.8	285.7	914	229*	533.4					
20	508.0	508.0	762.0	317.6	1016	254*	584.2	152.4	305.0	585	40	
22	558.8	558.8	838.2	343.0	1118	254*	641.4	152.4	305.0	642	40	
24	609.6	609.6	914.4	381.0	1219	305*	692.2	152.4	305.0	693	40	
26	660.0	660.0	991.0	405.0		267.0						
28	711.0	711.0	1067.0	438.0		267.0						
30	762.0	762.0	1143.0	470.0		267.0						
32	813.0	813.0	1219.0	502.0		267.0						
34	864.0	864.0	1295.0	533.0		267.0						
36	914.0	914.0	1372.0	565.0		267.0						
38	965.0	965.0	1448.0	600.0		305.0						
40	1016.0	1016.0	1524.0	632.0		305.0						
42	1067.0	1067.0	1600.0	660.0		305.0						
44	1118.0	1118.0	1676.0	695.0		343.0						
46	1168.0	1168.0	1753.0	727.0		343.0						
48	1219.0	1219.0	1829.0	759.0		343.0						
-	-	-	-	-		-						

* All dimensions are in mm

EDGE PREPRATON AS PER ANSI B 16.9 - B 16.25

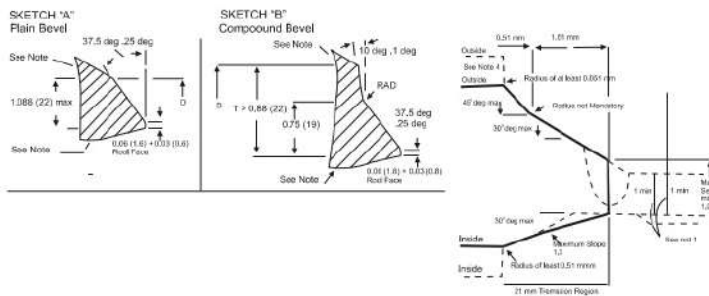

Normal Wall Thickness	End Preparation
Less than x*	Cut square or slightly Chamfer, at mrfs option
X* to 0.88 incl (22)	Chamfer, at mrfs option A above
More than 0.88 (22)	Compound bevel as in sketch B above
	X* = 0.19 (5) for Carbon Steel or Ferritic Alloy Steel and 0.12 (4) For Austenitic Alloy Steel

- The Value 1 min is whichever of the following is applicable:
 - the minim ordered wall thickness of the pipe;
 - 0.875 time the nominal wall thickness of pipe ordered to a pipe schedule wall thickness which has as under tolerance of 12.5%
 - The Maximum thickness at the end of the component is:
 - the greater of 1 min. + 0.15 in. (4 mm) or 1.15 in. (4 mm) or 1.15 t min, when ordered on a minimum wall basis
 - the greater of t min. + 0.15 in (4 mm) or 1.10 t nom. When ordered on a nominal wall basis
 - Weld bevel is shown for illustration only.
 - When transitions using maximum slope do no intersect outside surface, as shown by phantom outline, maximum Slopes shown or alternate radii shown in phantom outlines shall be used.
 - Dimension is parenthesis are in millimeters. Other are in inches.
- Note : 2. The shape of cap shall be ellipsoidal
 Note : 2. Of Specification ANSI b 16.9 for cap E1 & e2 to be consider
 Length E1 applies for thickness greater than that given in coloumn * Limiting Wall Thickness" for NPS 24 (DIN 600) & Smaller, For NPS 26 (DN 650) and larger, length E1 Shall by agreement between manufacturer and purchaser

* E1 Height



WE-LOCK CO.

DEVELOPING TOMORROW'S TODAY

AN ISO 9001 : 2008 / ISO 14001 / ISO 18001 CERTIFIED COMPANY

BUTT WELDING PIPE FITTING DIMENSIONAL STANDARD ANSI B-16.9 /16.28 / MSS SP-43

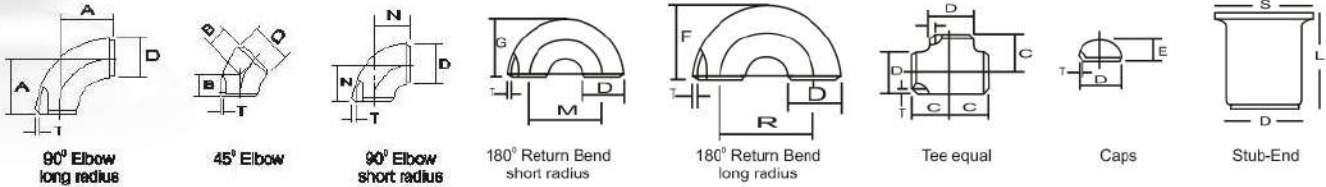

Nominal Pipe Size		Outside Diameter	Center to Face				Back to Face			Center to Center			Length 'L'	
Inch.	mm	D	A	B	C	N	E	F	G	R	M	S	MSS SP43	ANSI B 16.9
1/2	15	21.3	19	16	25	—	25	48	—	38	—	34.9	50.8	76.2
3/4	20	26.7	29	11	29	—	25	43	—	57	—	42.8	50.8	76.2
1	25	33.4	38	22	38	25	38	56	41	76	51	50.8	50.8	101.6
1 1/4	32	42.2	48	25	48	32	38	70	52	95	64	63.5	50.8	101.6
1 1/2	40	48.3	57	29	57	38	38	83	62	114	76	73	50.8	101.6
2	50	60.3	76	35	64	51	38	106	81	152	102	92	63.5	152.4
2 1/2	65	73.0	95	44	76	64	38	132	100	191	127	104.8	63.5	152.4
3	80	88.9	114	51	86	76	51	159	121	229	152	127	63.5	152.4
3 1/2	90	101.6	133	57	95	89	64	184	140	267	178	139.7	76.2	152.4
4	100	114.3	152	64	105	102	64	210	159	305	203	157.2	76.2	152.4
5	125	141.3	190	79	124	127	76	262	197	381	254	185.7	76.2	203.2
6	150	168.3	229	95	143	152	89	313	237	457	305	215.9	88.9	203.2
8	200	219.1	305	127	178	203	102	414	313	610	406	270	101.6	203.2
10	250	273.1	381	159	216	254	127	518	391	762	508	324	127.0	254.0
12	300	323.9	457	190	254	305	152	619	467	914	610	381	152.4	254.0
14	350	355.6	533	222	279	356	165	711	533	1067	711	412.8	152.4	305.0
16	400	406.4	610	254	305	406	178	813	610	1219	813	470	152.4	305.0
18	450	457.2	686	286	343	457	203	914	686	1372	914	533.4	152.4	305.0
20	500	508.0	762	318	381	508	229	1016	762	1524	1016	584.2	152.4	305.0
22	550	559.0	838	343	419	559	254	1118	838	1676	1118	614.4	152.4	305.0
24	600	610.0	914	381	432	610	267	1219	914	1829	1219	692.2	152.4	305.0
26	650	660.0	991	406	495	660	267	—	—	—	—	—	—	—
28	700	711.0	1067	438	521	711	267	—	—	—	—	—	—	—
30	750	762.0	1143	470	559	762	267	—	—	—	—	—	—	—
32	800	813.0	1219	502	597	813	267	—	—	—	—	—	—	—
34	850	864.0	1295	533	635	864	267	—	—	—	—	—	—	—
36	900	914.0	1372	565	673	914	267							
38	950	965.0	1448	600	711	965	305							
40	1000	1016.0	1524	632	749	1016	305							
42	1050	1067.0	1600	660	762	1067	305							
44	1100	1118.0	1676	695	813	1118	343							
46	1150	1168.0	1753	727	851	1168	343							
48	1200	1219.0	1829	759	889	1219	343							



WE-LOCK CO.

AN ISO 9001 : 2008 / ISO 14001 / ISO 18001 CERTIFIED COMPANY

DIMENSIONAL TOLERANCE ANSI B16.9/B16.28/MSS SP-43

ALL FITTINGS					90°/60°/45° 30° ELBOWS & TEES		REDUCERS		180° RETURNS				CAPS		ANGULARITY TOLERANCE		
Nominal Pipe size INCH/MM	Outside Diameter at Bevel	Inside Dia. Meter	Wall Thickness at End	Center to End	Overall Length Dimension		Center to End	Back to Face Dimension	Alignment of End Dimensions	Overall Length	Nominal Pipe Size	Off Angel Inch/mm	Off Plane				
					D	T								O	K	U	E
	(1) B16.9 MSS Sp43	(2) B16.9	B16.9 MSS SP43	B16.9 MSS SP43	B16.9 MSS SP43	B16.9 MSS SP43	B16.9 MSS SP43	B16.9 MSS SP43	B16.9 MSS SP43	B16.9 MSS SP43	B16.9 MSS SP43	B16.9 MSS SP75	B16.9				
1/2" - 2 1/2" 15 - 65	±1.6 -0.8		±0.8	FROM 1/2" TO 18" 15 TO 600	FROM 3/4" 15 - 600	FROM 1/2" - 24" 15 - 600	FROM 1/2" - 8" 15 - 200					±3	±3.17	1/2" - 4" 15 - 100	±1		±2
3" - 3 1/2" 80 - 90	±1.6	±0.80	±1.6	±2	±1.60	±2	±1.60	±6	±6.35	±6.0	±6.4	±1	±0.8	5" - 8" 125 - 200	±2	16" - 24" 400 - 600 1.6	±4
4" 100														±3	±5		
5" - 6" 125 - 150	+2.4 -1.6	+1.60 -0.80	±3.2	Not Less Than 87.5% Nominal Thk	Not Less Than 87.5% Nominal Thk	±2.40	10" - 24" +2.38 250 - 600	±10	±10			±2.0"	±1.60	14" - 16" 350 - 400	±3		±7
8" 200														±4	±10		
10" - 18" 250 - 450	+4 -3.2	+2.38 -0.80	±3.2											26" - 30" 650 - 750	±5	26" - 36" 650 - 900 2.4	±10
20" - 24" 500 - 600	+6.4 -4.8	3.17 0.79												32" - 42" 800 - 1050	±5		±13
26" - 30" 650 - 750	+6.4 -4.8	±4.8	±4.8	±3		FROM 26" - 45" 650NB - 1200 NB ±5							±10	44" - 48" 1100 - 1200	±5	32" - 48" 950 - 1200 3.2	±20
32" - 48" 800 - 1200	+6.4 -4.8			±5										42 - 48" 1050 - 1200	±5		±20

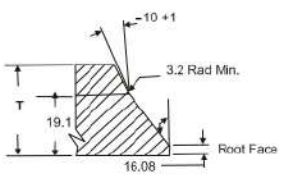
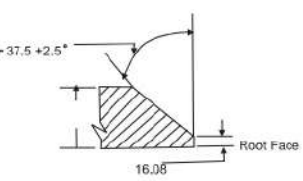
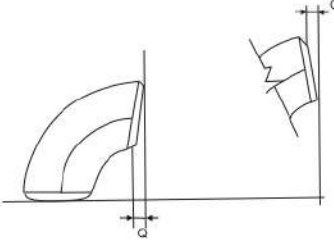
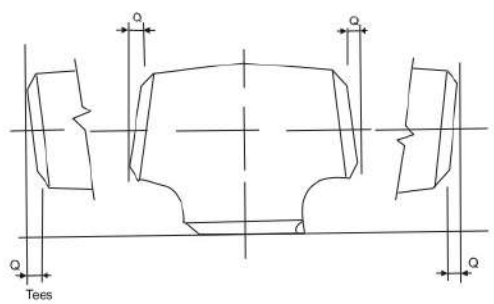
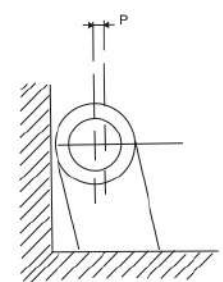
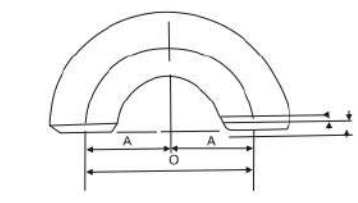
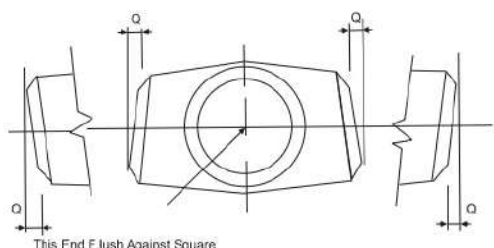



WE-LOCK CO.

AN ISO 9001 : 2008 / ISO 14001 / ISO 18001 CERTIFIED COMPANY

WEIGHTS OF FITTINGS 90 ELBOWS (L.R) BUTT-WELD (ANSI B16.9)

N B INCHES METRIC		(Weights in.KGS.)																
		SCH 5 S	SCH 10 S	SCH 10	SCH 20	SCH 30	SCH 40 S	SCH STD	SCH 40	SCH 60	SCH 80 S	SCH XS	SCH 80	SCH 100	SCH 120	SCH 140	SCH 160	SCH XXS
1/2	15	0.1	0.1	-	-	-	0.1	0.1	-	-	0.1	0.1	-	-	-	-	0.1	0.1
3/4	20	0.1	0.1	-	-	-	0.1	0.1	-	-	0.1	0.1	-	-	-	-	0.2	0.2
1	25	0.1	0.2	-	-	-	0.2	0.2	-	-	0.2	0.2	-	-	-	-	0.3	0.4
1-1/4	32	0.1	0.2	-	-	-	0.3	0.3	-	-	0.4	0.4	-	-	-	-	0.5	0.6
1-1/2	40	0.2	0.3	-	-	-	0.4	0.4	-	-	0.6	0.6	-	-	-	-	0.7	1.0
2	50	0.3	0.5	-	-	-	0.7	0.7	-	-	1.0	1.0	-	-	-	-	1.4	1.7
2-1/2	65	0.6	0.9	-	-	-	1.4	1.4	-	-	1.5	1.5	-	-	-	-	2.5	3.2
3	80	1.0	1.3	-	-	-	2.5	2.5	-	-	2.9	2.9	-	-	-	-	3.8	5.5
3-1/2	90	1.2	1.7	-	-	-	3.0	3.0	-	-	4.0	4.0	-	-	-	-	-	8
4	100	1.6	2.1	-	-	-	4.0	4.0	-	-	6.0	6.0	-	-	7.5	-	9	12
5	125	2.7	3.7	-	-	-	6.8	6.8	-	-	9.3	9.3	-	-	2.7	-	15	18
6	150	4.4	5.5	-	-	-	11	11	-	-	17	17	-	-	23	-	26	30
8	200	9	10	-	17	19	22	22	-	27	35	35	-	38	41	52	55	54
10	250	17	18	-	26	33	42	42	-	54	54	61	-	75	85	97	109	-
12	300	24	27	-	37	49	60	60	61	82	80	80	107	123	140	157	180	-
14	350	28	40	50	59	70	70	70	83	109	94	94	135	188	190	224	248	-
16	400	38	52	64	78	95	95	95	125	162	125	125	202	260	274	323	367	-
18	450	48	65	82	100	139	120	120	176	232	158	158	291	390	405	422	545	-
20	500	58	85	100	146	194	146	146	228	311	194	194	391	476	508	607	770	-
22	550	-	-	120	-	-	-	178	-	-	236	-	-	-	-	-	-	-
24	600	88	146	146	220	318	220	220	383	533	282	282	658	820	954	1100	1270	-

90 ELBOWS (S R) BUTT-WELD (ANSI B16.28)

N B INCHES METRIC		(Weights in.KGS.)															
		SCH 5 S	SCH 10 S	SCH 10	SCH 20	SCH 30	SCH STD	SCH 40	SCH 60	SCH XS	SCH 80	SCH 100	SCH 120	SCH 140	SCH 160	SCH XXS	
1/2	15	0.1	0.1	-	-	-	0.1	-	-	0.1	-	-	-	-	-	-	
3/4	20	0.1	0.1	-	-	-	0.1	-	-	0.1	-	-	-	-	-	-	
1	25	0.1	0.1	-	-	-	0.1	-	-	0.1	-	-	-	-	-	-	
1-1/4	32	0.1	0.2	-	-	-	0.2	-	-	0.3	-	-	-	-	-	-	
1-1/2	40	0.1	0.2	-	-	-	0.3	-	-	0.4	-	-	-	-	-	-	
2	50	0.2	0.4	-	-	-	0.5	-	-	0.7	-	-	-	-	-	-	
2-1/2	65	0.4	0.6	-	-	-	1.1	-	-	1.1	-	-	-	-	-	-	
3	80	0.8	1.0	-	-	-	2.0	-	-	2.0	-	-	-	-	-	-	
3-1/2	90	0.9	1.3	-	-	-	2.3	-	-	3.0	-	-	-	-	-	-	
4	100	1.2	1.6	-	-	-	3.0	-	-	4.2	-	-	4.5	-	-	-	
5	125	2.1	2.7	-	-	-	5.1	-	-	6.5	-	-	9	-	-	-	
6	150	3.3	4.1	-	-	-	8.3	-	-	11.8	-	-	13.5	-	-	-	
8	200	6.6	7.7	-	11.1	11.4	17	-	18.2	24.4	-	26.4	29	32	-	-	
10	250	12.5	13.6	-	17.4	21.4	31	-	37.7	37.7	41	50	53	62	-	-	
12	300	18	20.5	-	25.0	33.2	45	48	54.5	56.0	68	81	92	99	-	-	
14	350	21	30	38	39.5	52.5	52.5	55	74.0	66.0	94	124	120	138	-	-	
16	400	29	38.7	48	52.2	71.3	71.3	104	106.7	104.3	138	171	166	198	-	-	
18	450	36	49.1	62	65.4	92.2	90	118	154.4	110.6	193	257	283	387	-	-	
20	500	44	63.7	75	110	136	110	155	208.0	135.8	261	332	376	430	-	-	
22	550	-	-	90	-	-	-	-	-	-	-	-	-	-	-	-	
24	600	66	110	110	165	214.3	165	257	355.5	197.5	444	530	621	680	-	-	

WEIGHT ARE APPROXIMATE



WE-LOCK CO.

AN ISO 9001 : 2008 / ISO 14001 / ISO 18001 CERTIFIED COMPANY

WEIGHTS FITTINGS 45 DEG. ELBOWS BUTT-WELDED (ANSI B 16.9)

NB INCHES	SIZE MM	SCH 5 S	SCH 10 S	SCH 10	SCH 20	SCH 30	(WEIGHTS IN KGS.)				SCH 80 S	SCH X S	SCH 80	SCH 100	SCH 120	SCH 140	SCH 160	SCH XXS
							SCH 40 S	SCH STD	SCH 40	SCH 60								
1/2	15	0.1	.1	-	-	-	0.1	0.1	-	-	0.1	0.1	-	-	-	-	0.1	0.1
3/4	20	0.1	.1	-	-	-	0.1	0.1	-	-	0.1	0.1	-	-	-	-	0.1	0.1
1	25	0.1	.1	-	-	-	0.1	0.1	-	-	0.1	0.1	-	-	-	-	0.1	0.2
1 1/4	32	0.1	.1	-	-	-	0.1	0.1	-	-	0.2	0.2	-	-	-	-	0.2	0.3
1 1/2	40	0.1	.2	-	-	-	0.2	0.2	-	-	0.3	0.3	-	-	-	-	0.3	0.5
2	50	0.2	.3	-	-	-	0.4	0.4	-	-	0.5	0.5	-	-	-	-	0.7	0.9
2 1/2	65	0.3	.4	-	-	-	0.7	0.7	-	-	0.8	0.8	-	-	-	-	1.3	1.6
3	80	0.5	.6	-	-	-	1.3	1.3	-	-	1.5	1.5	-	-	-	-	2	2.5
3 1/2	90	0.6	.8	-	-	-	1.5	1.5	-	-	2.0	2.0	-	-	-	-	-	4
4	100	0.8	1.1	-	-	-	2.0	2.0	-	-	3.0	3.0	-	-	3.8	-	4.5	5
5	125	1.4	1.6	-	-	-	3.4	3.4	-	-	4.7	4.7	-	-	6.4	-	7.5	9
6	150	2.2	2.7	-	-	-	5.5	5.5	-	-	6.4	6.4	-	-	11.5	-	13	15
8	200	4.4	5.1	-	10	10	11	11	-	13.5	17.4	17.4	-	19	20.3	26	27.5	27
10	250	8.3	9.1	-	18.5	16	21	21	-	27	27	27	31	37.5	42.5	49	54.4	-
12	300	12	13.6	-	24.8	24.5	30	30	31	41	40	40	54	61.5	70	79	90	-
14	350	14	20	25	37	35	35	41	41	54.5	47	47	68	94	95	112	124	-
16	400	19	26	32	46.5	47.5	47.5	47.5	63	81	62.5	62.5	101	130	137	162	183	-
18	450	24	33	41	56	69.5	60	60	87	116	79	79	145	195	203	211	273	-
20	500	29	42.5	50	73	97	73	73	114	156	97	97	195	238	254	304	385	-
22	550	-	-	60	-	-	90	-	-	-	-	118	-	-	-	-	-	-
24	600	44	73	73	110	159	110	110	191	267	141	141	334	410	477	545	635	-

END CAPS BUTT-WELD (ANSI B 16.9)

NB INCHES	SIZE MM	SCH 5 S	SCH 10 S	SCH 10	SCH 20	SCH 30	(WEIGHTS IN KGS.)				SCH 80 S	SCH X S	SCH 80	SCH 100	SCH 120	SCH 140	SCH 160	SCH XXS
							SCH 40 S	SCH STD	SCH 40	SCH 60								
1/2	15	0.1	0.1	-	-	-	0.1	0.1	-	-	0.1	0.1	-	-	-	-	-	-
3/4	20	0.1	0.1	-	-	-	0.1	0.1	-	-	0.1	0.1	-	-	-	-	-	-
1	25	0.1	0.1	-	-	-	0.1	0.1	-	-	0.2	0.1	-	-	-	-	0.2	0.2
1 1/4	32	0.1	0.1	-	-	-	0.2	0.2	-	-	0.2	0.2	-	-	-	-	0.3	0.3
1 1/2	40	0.1	0.1	-	-	-	0.2	0.2	-	-	0.3	0.3	-	-	-	-	0.3	0.4
2	50	0.1	0.1	-	-	-	0.3	0.3	-	-	0.3	0.3	-	-	-	-	0.6	0.6
2 1/2	65	0.2	0.2	-	-	-	0.4	0.4	-	-	0.5	0.5	-	-	-	-	0.9	1
3	80	0.3	0.4	-	-	-	0.7	0.7	-	-	0.9	0.9	-	-	-	-	1.5	1.8
3 1/2	90	0.4	0.5	-	-	-	1	1	-	-	1.3	1.3	-	-	-	-	-	2.8
4	100	0.4	0.6	-	-	-	1.1	1.1	-	-	1.6	1.6	-	-	2.5	-	2.8	3.5
5	125	0.8	1	-	-	-	2	2	-	-	2.7	2.7	-	-	4	-	5	5.5
6	150	1.2	1.5	-	-	-	3	3	-	-	4.4	4.4	-	-	6	-	7.5	8.1
8	200	2.2	2.8	-	4.5	5	5.5	5.5	5.5	7	8.4	8.4	15.09	11	12.27	14	19	14.91
10	250	3.6	4.6	-	6	8	9	9	-	13	13.6	13.6	16.25	21	30	30	33	29.30
12	300	6	7.5	-	10	13	15	15	19	25.5	22.5	22.5	29.5	32.5	41	46	53	-
14	350	6.4	8.2	14	13.5	16	16	16	24	38	27	27	36.3	50	59	67	76	-
16	400	8.4	10.7	18	18	21	21	21	31	52	31.5	31.5	52.3	64	75	90	99	-
18	450	10.4	13	22	22	30	26	26	42	66	36	36	72.5	75	88	93	104	-
20	500	13.6	17	29	34	42	34	34	56.8	78	42	42	98.5	122	143	153	170	-
22	550	15	20	35.5	39	42	39	39	-	94.5	51	51	126	154	182	210	240	-
24	600	20.8	26	44	52	74.5	52	52	96.5	120	60	60	150	186	220	250	285	-

WEIGHT ARE APPROXIMATE



WE-LOCK CO.

AN ISO 9001 : 2008 / ISO 14001 / ISO 18001 CERTIFIED COMPANY

WEIGHTS OF FITTINGS EQUAL / UNEQUAL TEES BUTT-WELD (ANSI B 16.9)

N/B INCHES METRIC	SCH 5 S	SCH 10 S	SCH 10	SCH 20	SCH 30	(Weights in.KGS.)					SCH XS	SCH 80	SCH 100	SCH 120	SCH 140	SCH 160	SCH XXS	
						SCH 40 S	SCH STD	SCH 40	SCH 60	SCH 80 S								
1/2	15	0.1	0.1	-	-	-	0.2	0.2	-	-	0.3	0.3	-	-	-	0.3	0.3	
3/4	20	0.1	0.1	-	-	-	0.2	0.2	-	-	0.4	0.4	-	-	-	0.5	0.5	
1	25	0.2	0.3	-	-	-	0.4	0.4	-	-	0.5	0.5	-	-	-	0.9	0.7	
1 1/4	32	0.4	0.5	-	-	-	0.9	0.9	-	-	1.1	1.1	-	-	-	1.3	1.2	
1 1/2	40	0.6	0.7	-	-	-	1.4	1.4	-	-	1.5	1.5	-	-	-	1.9	2.0	
2	50	0.7	1.7	-	-	-	1.7	1.7	-	-	2.2	2.2	-	-	-	3.2	3.0	
2 1/2	65	1.1	2.2	-	-	-	2.7	2.7	-	-	3.0	3.0	-	-	-	4.0	4.5	
3	80	1.5	3.0	-	-	-	3.8	3.8	-	-	3.8	3.8	-	-	-	6.6	7.1	
3 1/2	90	2.0	4.1	-	-	-	5.0	5.0	-	-	5.3	5.3	-	-	-	-	11	
4	100	2.6	4.4	-	-	-	6.5	6.5	-	-	7.7	7.7	-	-	9	17	15	
5	125	4.0	7.4	-	-	-	10	10	-	-	13.5	13.5	-	-	18	25	24	
6	150	6.4	12.4	-	-	-	16	16	-	-	19.3	19.3	-	-	24	40	38	
8	200	10.7	20.0	-	23	25	27	27	-	32	33	33	-	44	50	54	71	68
10	250	18.0	28.2	-	35	40	45	45	-	60	60	60	68	74	93	99	120	-
12	300	26.0	47.5	-	59	57	65	65	71	95	78	78	115	136	150	176	184	-
14	350	40.7	69.9	87.2	95	102	102	102	105	135	115	115	165	206	240	275	300	-
16	400	44	72.7	90.8	100	110	110	110	167	206	167	167	249	335	330	385	420	-
18	450	54	101.7	127.1	127	164	135	135	237	277	190	190	322	380	450	500	500	-
20	500	67	169.8	199.8	168	245	168	168	320	379	245	245	459	540	590	720	790	-
22	550	-	-	220	-	-	-	220	-	-	-	280	-	-	-	-	-	-
24	600	100	306.5	310.0	240	373	240	240	571	654	350	350	748	910	1100	1180	1310	-

CON. / ECC. REDUCER BUTT-WELD (ANSIB16.9)

N/B INCHES METRIC	SCH 5 S	SCH 10 S	SCH 10	SCH 20	SCH 30	(Weights in.KGS.)					SCH XS	SCH 80	SCH 100	SCH 120	SCH 140	SCH 160	SCH XXS	
						SCH 40 S	SCH STD	SCH 40	SCH 60	SCH 80 S								
3/4	20	0.1	0.1	-	-	-	0.1	0.1	-	-	0.1	0.1	-	-	-	0.2	0.2	
1	25	0.1	0.1	-	-	-	0.1	0.1	-	-	0.2	0.2	-	-	-	0.2	0.2	
1 1/4	32	0.1	0.1	-	-	-	0.2	0.2	-	-	0.2	0.2	-	-	-	0.3	0.3	
1 1/2	40	0.1	0.2	-	-	-	0.3	0.3	-	-	0.4	0.4	-	-	-	0.5	0.5	
2	50	0.1	0.2	-	-	-	0.4	0.4	-	-	0.6	0.6	-	-	-	1.0	0.9	
2 1/2	65	0.3	0.4	-	-	-	0.8	0.8	-	-	1.0	1.0	-	-	-	1.4	1.4	
3	80	0.4	0.5	-	-	-	1.0	1.0	-	-	1.4	1.4	-	-	-	1.9	1.8	
3 1/2	90	0.6	0.7	-	-	-	1.3	1.3	-	-	1.9	1.9	-	-	-	3.9	3.2	
4	100	0.7	0.8	-	-	-	1.6	1.6	-	-	2.3	2.3	-	-	3.7	3.7	6.4	
5	125	1.1	1.4	-	-	-	2.8	2.8	-	-	3.9	3.9	-	-	6.4	6.4	9.0	
6	150	1.6	2.0	-	-	-	4.0	4.0	-	-	5.9	5.9	-	-	8	10	14.5	
8	200	2.8	3.3	-	5.0	6	6.5	6.5	-	8	10	10	-	12	14	16	16.5	-
10	250	4.3	5.5	-	7.3	9	10.7	10.7	-	14.5	15	15	17.7	21	25	28	29.5	-
12	300	6.0	7.7	-	9.7	13	15.0	15.0	16.4	22.3	20	20	28.2	33	38	44	49	-
14	350	10.8	13.8	23	22.3	27	26.9	26.8	31.3	41.8	36	36	52.3	64	73	78	86	-
16	400	13.3	16.4	28	27.5	33	33.2	33.1	44.0	56.6	44	44	73.5	83	97	112	121	-
18	450	16.0	20.3	34	33.5	47	40.0	40.0	59.5	77.4	53	53	97.6	116	136	145	159	-
20	500	23.8	29.8	50	59.5	79	59.4	59.4	93.0	125	79	79	159	163	178	305	340	-
22	550	-	-	57	-	-	-	-	-	-	-	87	-	-	-	-	-	-
24	600	28.7	36.3	63	71.7	107	71.7	71.7	129.4	181	95	95	228	241	295	540	610	-

WEIGHT ARE APPROXIMATE



DEVELOPING TOMORROW'S TODAY

WE-LOCK CO.

AN ISO 9001 : 2008 / ISO 14001 / ISO 18001 CERTIFIED COMPANY

REG OFFICE:- 184/186 MINARA MANSION, SVP ROAD, NEAR ROUND TEMPLE, MUMBAI
400004, MAHARASHTRA, INDIA.

WORKS: Plot 2808, G.I.D.C, UMERGAON DIST: VALSAD , GUJRAT, INDIA

Tel: +91 22 2389 1628

Fax: +91 22 2389 1628

Mob: +91 8484 90 2820 / 91 950 117 8117

Email: sales@we-lock.in

Web: www.we-lock.in

MANUFACTURER, EXPORTER OF BUTTWELD FITTINGS IN SS, CS, COPPER, NICKEL ALLOYS
WITH QAP & MTC.